

iSE

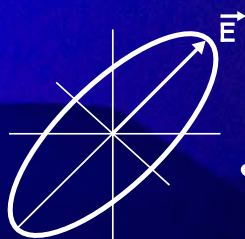
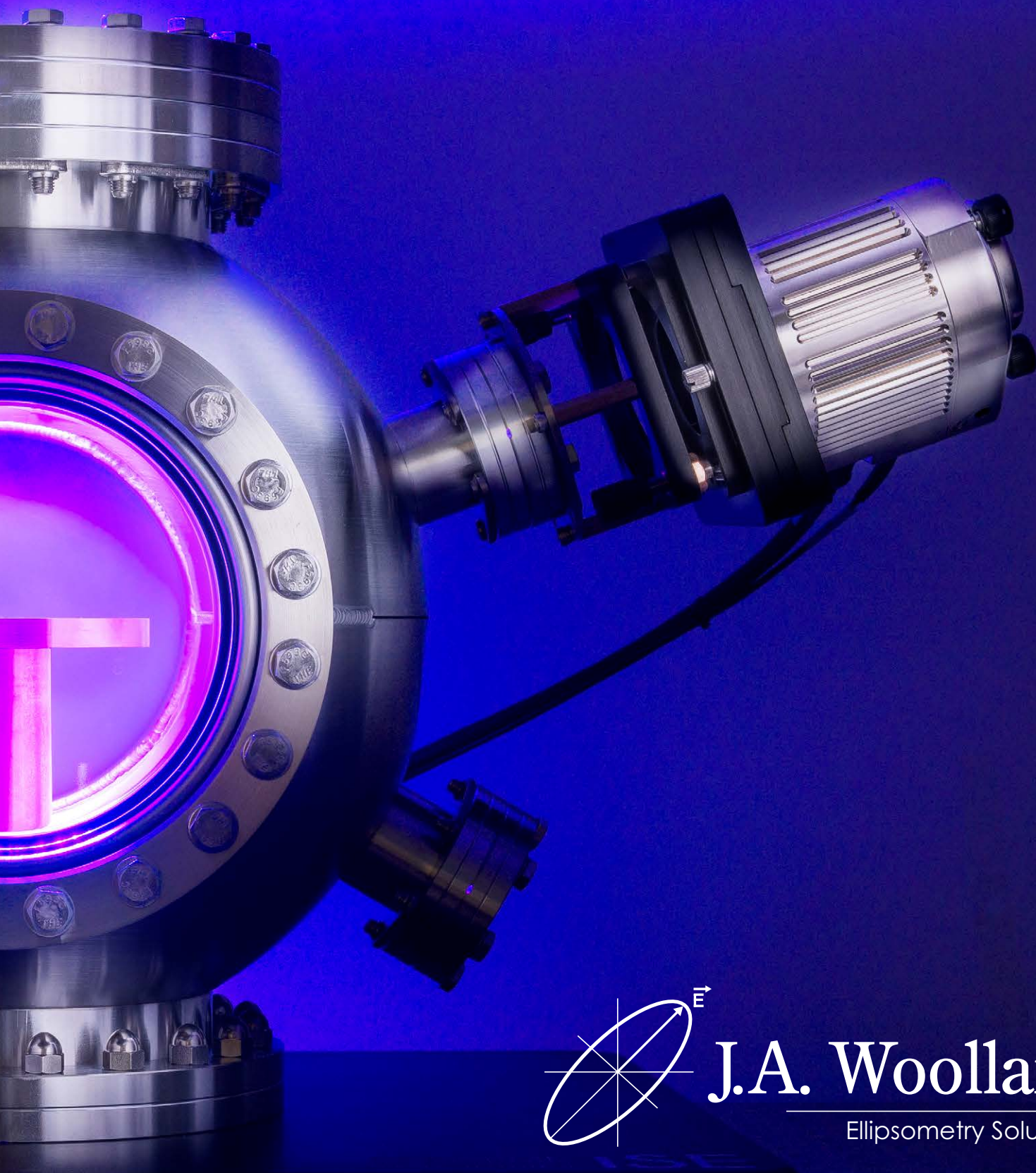

J.A. Woollam

Ellipsometry Solutions

Capabilities

The iSE is a new in-situ spectroscopic ellipsometer developed for real-time monitoring of thin film processing. Using our proven technology, the iSE enables users to optimize optical properties of deposited films, control film growth with sub-angstrom sensitivity, and monitor growth kinetics.

Why an iSE?

Powerful

With the power of spectroscopic ellipsometry (SE), the iSE is capable of measuring thickness and optical properties with much higher certainty than other techniques.

Compact

New compact design enables easy integration onto any chamber.

Versatile

Accurately determines thickness and optical properties for wide variety of thin films including metals, semiconductors, oxides, nitrides, and more.

Affordable

The power of spectroscopic ellipsometry at a reasonable price.

Easy-to-Use

User-friendly interface for real-time analysis of thin film growth and etch.



Advantages

Fast, Wide-Spectrum Measurements

The iSE utilizes a new optical design with Dual-Rotation™ in combination with modern CCD detection to provide hundreds of wavelengths in a fraction of a second. Dual-Rotation enables continuous, multi-zone measurements with unparalleled accuracy and capability.

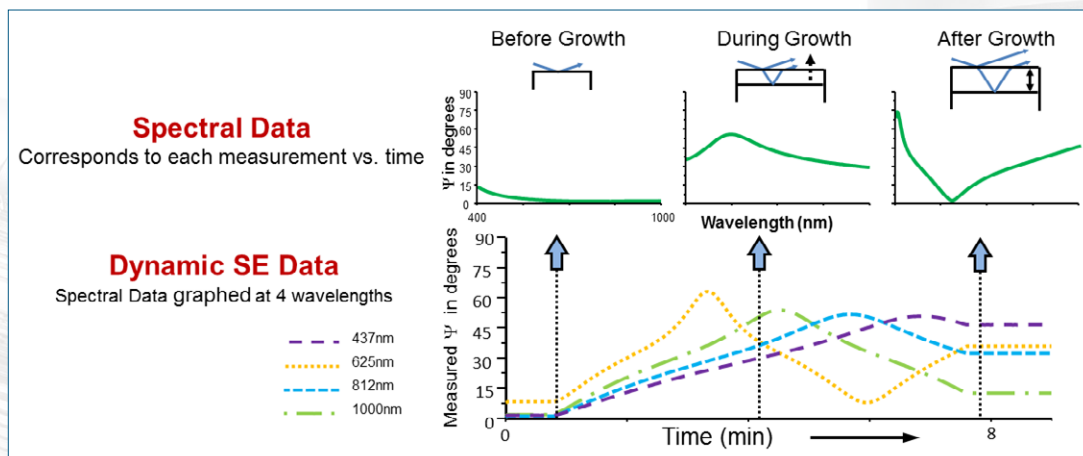

Figure 1. Dynamic spectroscopic ellipsometry data is graphed at four representative wavelengths. Each measurement versus time actually consists of 190 wavelengths from ultraviolet to near infrared. A few time points are graphed above, showing the SE data before, during, and after film growth.

High Sensitivity: Ellipsometry measurements over a wide spectral range provide sensitivity to a variety of material properties such as composition, conductivity, surface conditions, etc. In addition, ellipsometry is sensitive to thickness changes at the sub-angstrom level.

Real-Time: Monitors changes in film thickness and optical properties during deposition. Use these measurements for feedback control.

Non-Destructive: In-situ SE uses light to probe the thin film in a noninvasive manner. The ellipsometer is outside the process chamber and light is allowed to enter through windows and interact with the sample. The light beam directly measures surface of interest without any damage or need for special sample preparation.

Accurate: SE measurements calculate the change in polarization of light. For real-time measurements, this has significant advantages over intensity-based measurements:

- Data accuracy is not affected by coated windows
- Collects accurate data even without collecting the entire beam
- Polarization contains phase measurements which are highly sensitive to very thin films

Common Real-Time Ellipsometry Measurements

- Thin film thickness from single or multiple layers (Figure 2)
- Growth or etch rates
- Process kinetics
- Optical constants (Figure 3)
- Surface quality before and after processing
- Film nucleation behavior
- Process conditions that affect optical constants (deposition rate, temperature, pressure, etc.)
- Real-time end-point detection

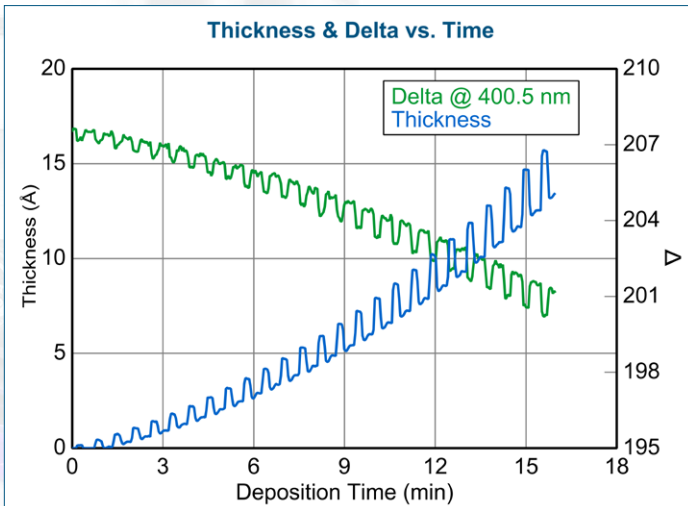

Figure 2. ALD film growth increasing in the first 25 cycles of deposition shown alongside changes in the raw ellipsometry data.

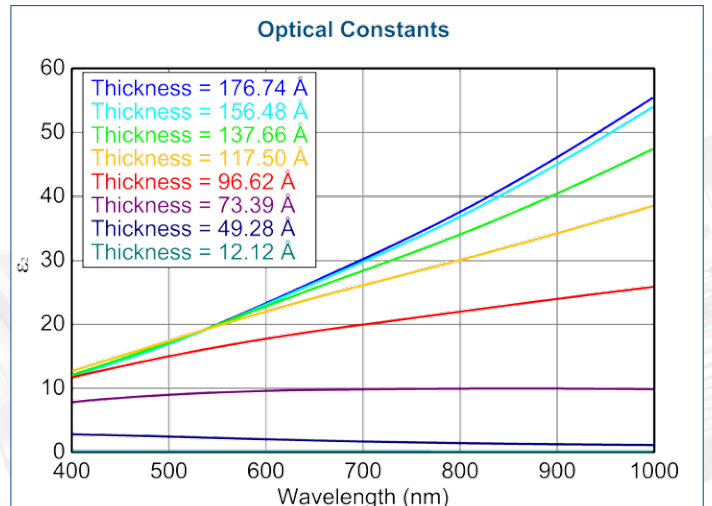

Figure 3. Optical properties and thickness of a metallic film changing as a function of deposition time.

Efficient Process Characterization

A common application of real-time SE involves monitoring an entire series of thin films during a single process. Each film is produced with varying conditions, which enables a quick understanding of the deposition process. Optical constants and growth rate are determined from each layer to characterize the process.

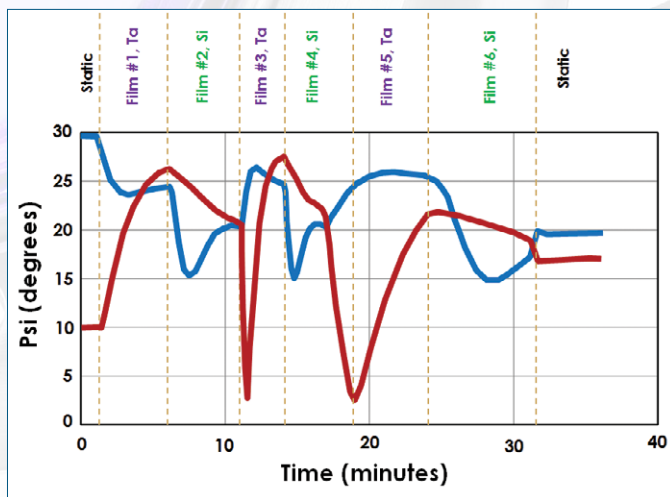

Figure 4. In-situ SE data (only two wavelengths) is shown above. The process varied between different film types and different process conditions. In this manner, a multi layer structure was characterized with information obtained from each individual film.

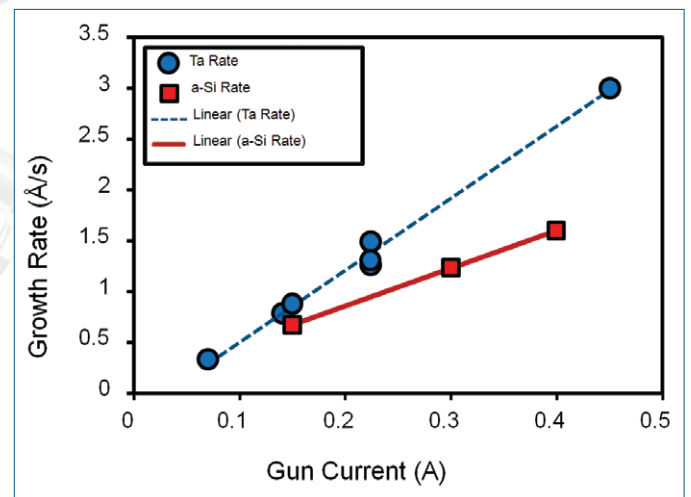

Figure 5. The optical constants and growth rate were determined for both Ta and a-Si films versus varying deposition conditions.

Specifications

Spectral Range

400 nm to 1000 nm, 190 wavelengths

Data Acquisition Rate

0.3 sec. [Fastest]
1-2 sec. [Typical]

System Overview

Dual-Rotation™ optical design
with CCD detection

Beam Diameter

Collimated: ~3 mm

Package Includes

Source and Receiver
Control Box
Tilt Stage Mounts
Calibration Base
2.75" Optical Viewports
CompleteEASE Software

Data Types

Spectroscopic ellipsometry and advanced
g-SE or MM-SE

Dimensions

Receiver unit shown, including chamber
mount and tilt stage

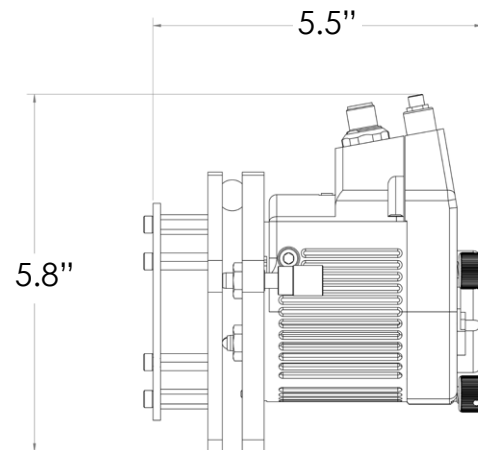

Chamber Requirements

Port Size: 1.33" or 2.75"

Typical Port Angle: 60°-75°*

*measured from sample normal

